

Media Pack 2016

D a i L Y m e D I a

D a i L Y m e D I A

Daily Media Sàrl is a publishing company based in Geneva, Switzerland, **covering all areas of modern culture of the 21st century**. Since 2004, the newspapers Daily Rock and Daily Movies are published and distributed by the company. Daily Media is also active in the area of **digital media** through its various websites. Our websites, whether they are standalone sites or supplement to our newspapers, **draw an ever growing number of engaged readers** of different ages, genders and social backgrounds.

With a young and passionate team, Daily Media Sàrl adapts its contents to new trends and may create **synergies between its different medias** in keeping with the increasingly transmedial evolution of cultural production.

Daily Media, your gateway to the world of today's... and tomorrow's culture !



Contents

Our printed newspapers

Daily Rock	5
Distribution & highlights	6
Technical information	7
Target audience	8
Festival Special	9
Distribution	10
Daily Movies	11
Distribution & highlights	12
Technical information	13
Target audience	14
Distribution	15
Newspaper ad size and pricing	16

Our online media

Daily Rock Suisse	20
Daily Rock France	21
Daily Rock Québec	22
Daily Movies	23
Daily Books	24
Daily Games	25
Daily Multimédia	26
Target audience	27
Online ad size and pricing	28

Our additional services

Translations	31
Photography	32
Graphic design	33
Daily Promotion	34
Contacts	35

Our printed newspapers



Daily Rock

Daily Rock is a newspaper about rock music distributed throughout the French-speaking part of Switzerland, in Ticino, in some German-speaking cities in Switzerland, and in the neighbouring part of France. The newspaper has a print run of 30,000 copies in full colour.

All styles are covered, from **Blues Rock** to **Metal** through **Punk, Stoner, Ska** and many others. Swiss bands play a big role. The focus is on the news and calendar of upcoming concerts, but there are also albums reviews, interviews and photo coverage and reports about bands, clubs, labels, etc.

Contact: David MARGRAF // (+41)227962361 // marketing@daily-rock.com

Distribution & Highlights



Daily Rock is available **by subscription on a wide variety of offers** which are frequently renewed.

The newspaper can also be found **in many shops**: record stores, FNAC, Media Markt, specialized shops, tattoo studios and **in nightlife places** such as bars, clubs, festivals and concert halls.

The **highlights** of Daily Rock are as follows:

- It is the only newspaper about rock music news in the French-speaking part of Switzerland
- Varied content
- Different rock styles are covered
- The news is also published on www.daily-rock.com
- Supports local artists
- Attractive prices for advertising
- Great visibility through the company's various media
- We are a passionate team
- Regular competitions
- Free distributed newspaper or available by subscription
- More than 200 distribution points throughout the French-speaking and German-speaking parts of Switzerland, Ticino and in the neighbouring part of France

Technical information

Information

Issues:	9 issues per year
Number of pages:	16 pages
Print size:	315x470 mm
Circulation:	30'000 copies
Price:	distributed free or available by subscription

Printing

Printing:	offset web press - Halftone 60
Advertising files:	files are sent by email
Pictures:	PDF format of 300 ppp in CMYK with an edge of 3 mm.

Release dates

Number	Release date	Deadline for sending advertising files
Daily Rock 91	February 1	January 15
Daily Rock 92	March 1	February 15
Daily Rock 93	April 1	March 15
Daily Rock 94	May 1	April 15
Daily Rock 95*	June 1	May 15
Festival Special*	June 1	May 15
Daily Rock 96	September 1	August 15
Daily Rock 97	October 1	September 15
Daily Rock 98	November 1	October 15
Daily Rock 99	December 1	November 15

* The June issue with the Festival Special supplement has a print-run of 50'000 copies.

Target audience

Of the total Daily Rock's audience
38% are females and 62% are males.
The majority are between 25 and 35 years old.

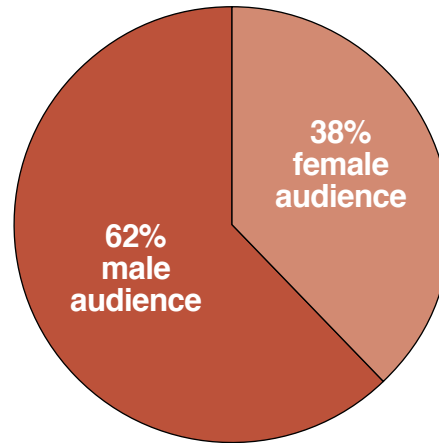

Age groups of Daily Rock's male audience

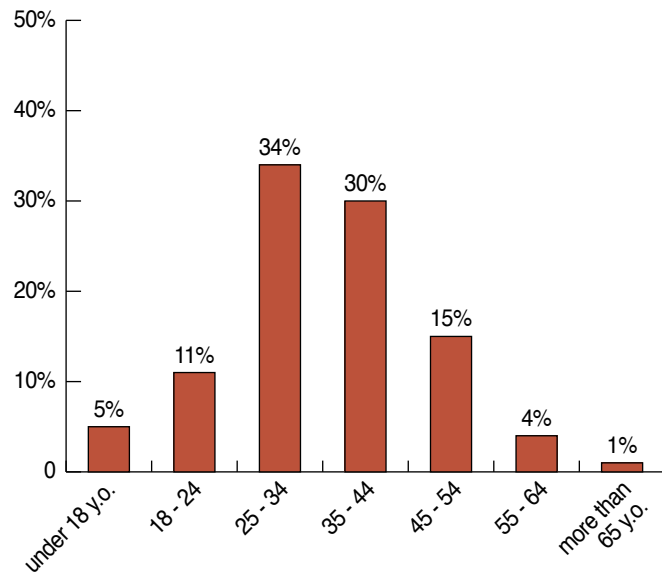

Age groups of Daily Rock's female audience

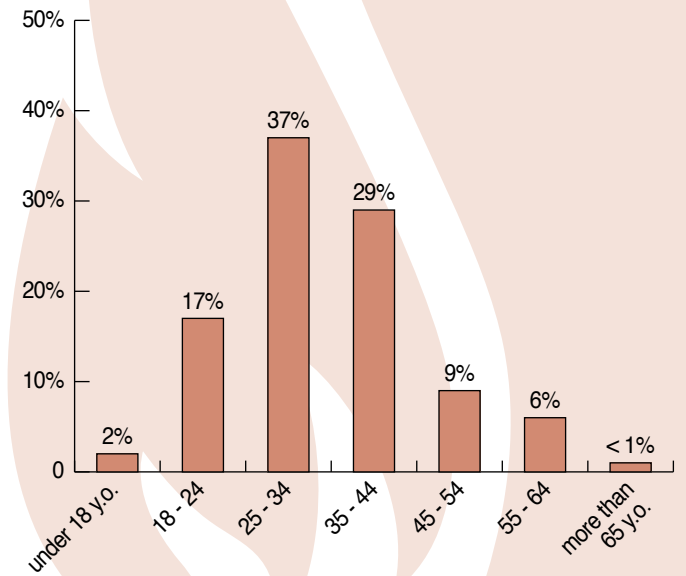

Festival Special



Since 2010, Daily Rock releases a **special issue of 16 pages dedicated to summer festivals** each June.

50,000 copies are distributed throughout the French-speaking and German-speaking parts of Switzerland, Ticino and in the neighbouring part of France.

Every year, our 32-pages newspaper features articles about twenty **Swiss and international festivals**.

Special offers are available to festivals and to advertisers.

Since 2013 the festival special is also available in a separate **German version** which has a print run of 30,000 copies.

Distribution

- Cities covered by Daily Rock



Daily Movies

Daily Movies is a movie newspaper distributed throughout the French-speaking part of Switzerland. The newspaper has a print run of 30,000 copies in full color.

All film styles are covered, from blockbusters to independent films through Asian cinema, animation movies and everything that makes the wide variety of movie art.

Special attention is given to the Swiss film production and festivals and we keep the reader informed about current news and happenings. The focus is on news and upcoming releases, interviews, articles about actors/directors/ movies, DVD/Bluray news, soundtrack and other kinds of films (B Movies, foreign movies, rediscovered old movies). Daily Movies likes to offer a wide variety of movies to its readers.

Contact: Carlos MÜHLIG // (+41)227962361 // marketing@daily-movies.ch

Distribution & Highlights



Daily Movies is available **by subscription on a wide variety of offers** which are frequently renewed.

The newspaper can also be read in festivals and cultural events, in theatres, Pathé Romandie, FNAC, Media Markt, schools, colleges etc.

The **highlights** of Daily Movies include :

- 100% movies
- Original newspaper format
- Diversity of contents
- All movie styles are covered
- The news are also published on www.daily-movies.ch
- It actively supports Swiss cinema
- Attractive prices for advertising
- Great visibility through the company's various media
- We are a passionate team
- Many contests
- Free distributed newspaper or available by subscription
- More than 200 distribution points throughout the French-speaking part of Switzerland

Technical information

Information

Issues :	9 issues per year
Number of pages :	16 pages
Print size :	315x470 mm
Circulation :	30'000 copies
Price :	distributed free or available by subscription

Printing

Printing :	offset web press - Halftone 60
Advertising files :	files are sent by email
Pictures :	PDF format of 300 ppp in CMYK with an edge of 3 mm.

Release dates

Number	Release date	Deadline for sending advertising files
Daily Movies 67	February 1	January 15
Daily Movies 68	March 1	February 15
Daily Movies 69	April 1	March 15
Daily Movies 70	May 1	April 15
Daily Movies 71	June 1	May 15
Daily Movies 72	September 1	August 15
Daily Movies 73	October 1	September 15
Daily Movies 74	November 1	October 15
Daily Movies 75	December 1	November 15

* The June issue will be an special issue dedicated to Open air cinéma in the French-speaking part of Switzerlad with a circulation of 50,000 copies.

Target audience

Of the total Daily Movies' audience
52% are females and 48% are males.
The majority are between 25 and 35 years old.

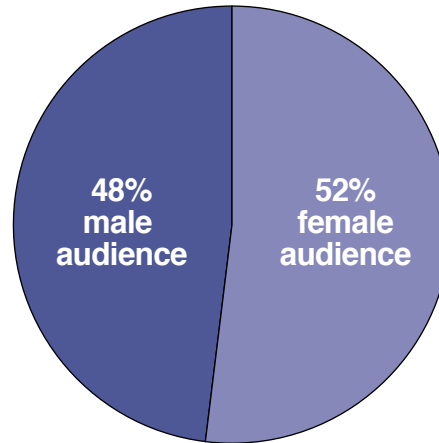

Age groups of Daily Movies' male audience

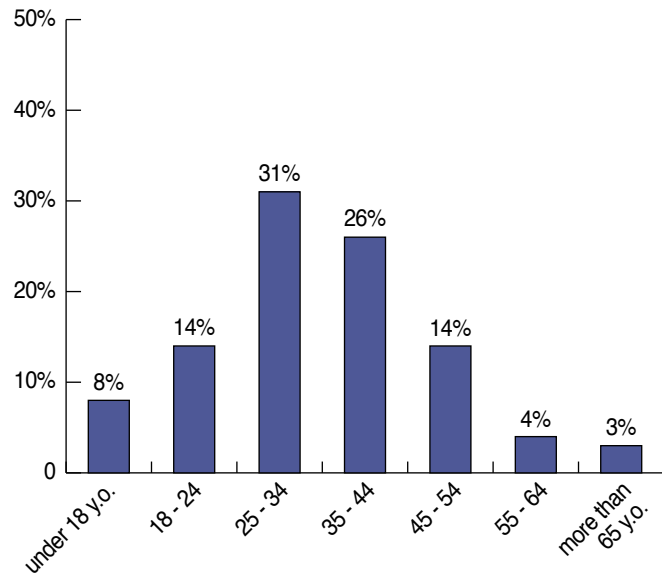

Age groups of Daily Movies' female audience

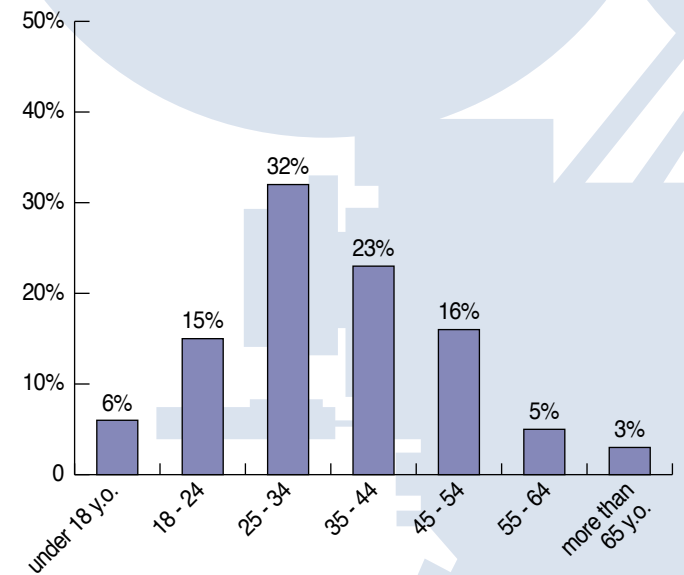

Distribution

- Cities covered by Daily Movies



Newspaper ad size and pricing in Daily Rock & Daily Movies (1/3)

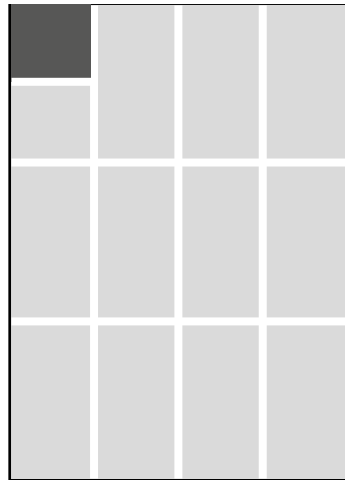

« Half standard » insert 65x65 mm

Advertisers prices

1 release	300 CHF
3 releases	3x 150 CHF
10 releases	10x 99.9 CHF

Support/partner prices*

1 release	150 CHF
3 releases	3x 100 CHF
10 releases	10x 66.6 CHF

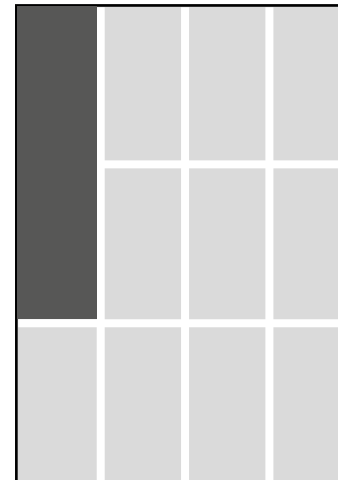

« Double standard » insert 65x270 mm

Advertisers prices

1 release	1'000 CHF
3 releases	3x 700 CHF
10 releases	10x 500 CHF

Support/partner prices*

1 release	600 CHF
3 releases	3x 400 CHF
10 releases	10x 300 CHF

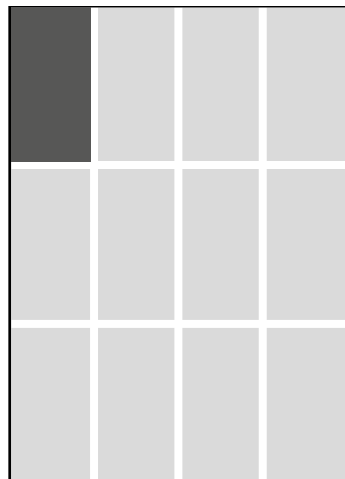

« Standard » insert 65x130 mm

Advertisers prices

1 release	500 CHF
3 releases	3x 350 CHF
10 releases	10x 250 CHF

Support/partner prices*

1 release	300 CHF
3 releases	3x 250 CHF
10 releases	10x 150 CHF

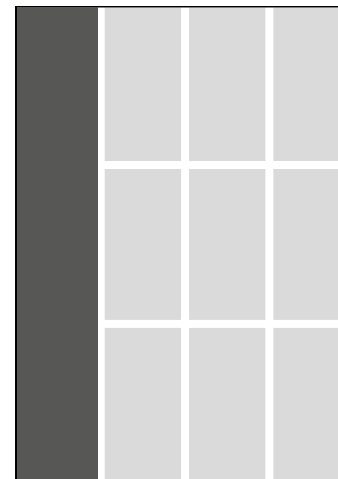

« Triple standard » insert 65x410 mm

Advertisers prices

1 release	1'500 CHF
3 releases	3x 1'100 CHF
10 releases	10x 750 CHF

Support/partner prices*

1 release	900 CHF
3 releases	3x 600 CHF
10 releases	10x 500 CHF

Other formats : information available on request. The indicated prices are in Swiss francs (CHF) exclusive of the 8% VAT.

* The support/partner prices are especially for clubs, labels, bands, film industry professionals (producers, distributors, video stores, festivals, ...)

We can create your ad for an extra cost of 20%.

Newspaper ad size and pricing in Daily Rock & Daily Movies (2/3)

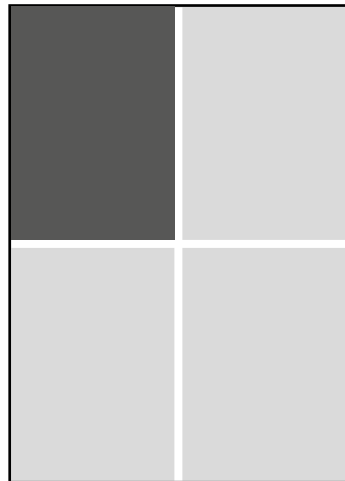

Quarter page 139x200 mm

Advertisers prices

1 release	1'500 CHF
3 releases	3x 1'100 CHF
10 releases	10x 750 CHF

Support/partner prices*

1 release	900 CHF
3 releases	3x 600 CHF
10 releases	10x 500 CHF

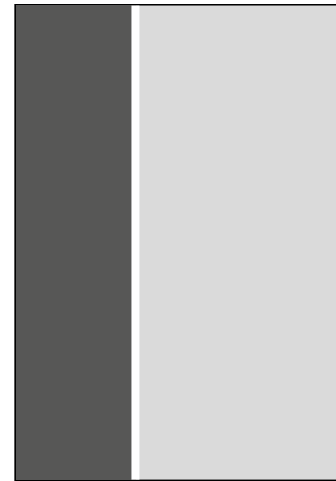

1/3 page vertical 89,3x410 mm

Advertisers prices

1 release	1'950 CHF
3 releases	3x 1'450 CHF
10 releases	10x 950 CHF

Support/partner prices*

1 release	1'200 CHF
3 releases	3x 950 CHF
10 releases	10x 750 CHF



Half page 285x201 mm

Advertisers prices

1 release	2'600 CHF
3 releases	3x 1'950 CHF
10 releases	10x 1'300 CHF

Support/partner prices*

1 release	1'500 CHF
3 releases	3x 1'100 CHF
10 releases	10x 950 CHF



1/3 page horizontal 285x130 mm

Advertisers prices

1 release	1'950 CHF
3 releases	3x 1'450 CHF
10 releases	10x 950 CHF

Support/partner prices*

1 release	1'200 CHF
3 releases	3x 950 CHF
10 releases	10x 750 CHF

Other formats : information available on request. The indicated prices are in Swiss francs (CHF) exclusive of the 8% VAT.

* The support/partner prices are especially for clubs, labels, bands, film industry professionals (producers, distributors, video stores, festivals, ...)

We can create your ad for an extra cost of 20%.

Newspaper ad size and pricing in Daily Rock & Daily Movies (3/3)



The front page 212x100 mm

Advertisers prices

1 release	2'100 CHF
3 releases	3 x 1'850 CHF
10 releases	10 x 1'450 CHF

Support/partner prices*

1 release	1'500 CHF
3 releases	3 x 1'350 CHF
10 releases	10 x 1'100 CHF



Full page 285x410 mm

Advertisers prices

1 release	3'950 CHF
3 releases	3 x 3'250 CHF
10 releases	10 x 2'950 CHF

Support/partner prices*

1 release	2'500 CHF
3 releases	3 x 2'250 CHF
10 releases	10 x 1'950 CHF

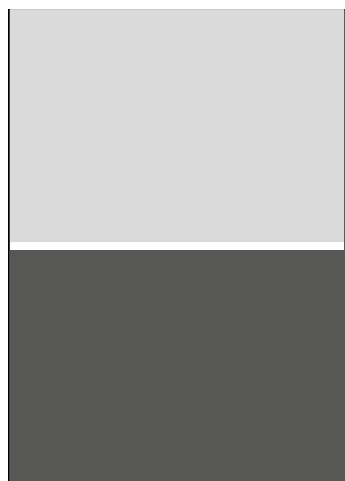

Half page back over 285x201 mm

Advertisers prices

1 release	2'900 CHF
3 releases	3 x 2'500 CHF
10 releases	10 x 1'950 CHF

Support/partner prices*

1 release	2'100 CHF
3 releases	3 x 1'750 CHF
10 releases	10 x 1'250 CHF

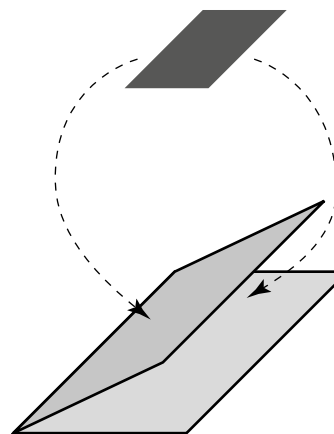

Inserts Flyers, stickers, CD, etc.

Flyer, sticker or postcard included

Under the plastic package	
100 pieces	25 CHF
Inside the newspaper	
100 pieces	45 CHF

CD included

Under the plastic package	
100 pieces	50 CHF
Inside the newspaper	
100 pieces	70 CHF

Other formats : information available on request. The indicated prices are in Swiss francs (CHF) exclusive of the 8% VAT. We can create your ad for an extra cost of 20%.

* The support/partner prices are especially for clubs, labels, bands, film industry professionals (producers, distributors, video stores, festivals, ...)

Our online media





The Daily Rock's website is **the perfect complement** to the printed newspaper. Updated daily, the site offers additional articles, **complete interviews** (which are frequently shortened in the newspaper), **photo galleries**, videos, **news**, details of upcoming concerts **and many other additional topics**.

The Website benefits from a high visibility every month in the French-speaking part of Switzerland and in many German-speaking Swiss cities, in Ticino and in the neighbouring part of France because of **the promotion of our newspaper**. All old issues are **fully available online**, stored in pdf files.

Highlights :

- Daily updated website
- Regular competitions
- Great visibility through the company's various media
- A variety of different rock styles
- Focused on Swiss Rock
- Social media distribution
- Average audience age : 15 to 55 years old
- 86'000 visitors per month

Contact: David MARGRAF // (+41)227962361 // marketing@daily-rock.com



Daily Rock France was launched in late February 2012. Now, DRF has grown into a **Webzine which receives about 10,000 visitors per month***, working in a cross-functional approach with Daily Rock Québec and Daily Rock Switzerland. **The Website's content is frequently included in the printed newspaper.**

With a team of fifteen columnists and photographers, we go to Festivals and concerts who open their doors to us **across the country** (Hellfest, Sonisphere, Les Vieilles Charrues and many others ...), **and interview French and international artists.** Our reviews include albums from famous artists and bands as well as up-and-coming French artists.

Daily Rock explores the whole spectrum of today's rock music.

Contact: David MARGRAF // (+41)227962361 // marketing@daily-rock.com



Since 2010, Daily Rock does not stop at European borders and sets out **to conquer French-speaking Canada** in order to spread the word.

We function as a Webzine, with about 14,000 unique visitors per month*, **publishing new interviews, high-quality photos, the latest news from local and international bands** who honour us with their presence in our magazine!

A team of about a dozen reporters and photographers frequently go to concerts and festivals (**Metropolis, Club Soda, Festival d'été de Québec, Heavy MTL**) in order to stay up-to-date and to let our readers discover or rediscover artists.

Contact: David MARGRAF // (+41)227962361 // marketing@daily-rock.com



The Daily Movies website is **the perfect complement** to the printed newspaper. Updated daily, the site offers additional articles, **complete interviews** (which are frequently shortened in the newspaper), photo galleries, videos, **news, an agenda of release dates in theaters** and many other additional topics.

The Website benefits from a high visibility every month in the French-speaking part of Switzerland because of **the promotion of our newspaper**. All old issues are **fully available online**, stored in pdf files.

Highlights :

- Daily updated website
- Regular competitions
- Great visibility through the company's various media
- Different movie styles are covered
- Focused on Swiss movies
- Social media distribution
- Average audience age : 15 to 55 years old
- 115'000 visitors per month

Contact: Carlos MÜHLIG // (+41)227962361 // marketing@daily-movies.ch



The Daily Books website is dedicated to **modern literary culture** and covers everything **from comic books and Manga to children's books**.

The daily updated website of Daily Books, which represents **one of the few Swiss media in this area**, offers numerous sections and various topics in order to attract **the purists as well as the whole family**. It provides details of all the newest French-speaking cultural events related to books, nationally and internationally, through its conscientious and passionate team.

Highlights :

- Daily updated website
- Broad range of readers
- Regular competitions
- Rich and varied content
- A new platform with an attractive design
- Great visibility through the company's various media
- A conscientious and passionate team
- Social media distribution
- All literary styles are covered

Editorial contact: Romain KAPPS // bede@daily-books.com

Marketing contact: Claude TALABER // (+41)227962361 // claudio@daily-media.ch



The website of Daily Games is dedicated to **video games culture**. It covers national and international news of video games (games, consoles, new technologies, learning, etc.) through comprehensive testing, reports, news, previews and contests.

The frequently updated website of Daily Games provides a wide range of sections, in order to attract **serious gamers, as well as casual gamers, families and their children**.

Through its diversity, its closeness and eclectic approach, the Daily Games website attracts **even more readers**.

Highlights :

- Frequently updated website
- Diversity of its readers
- Regular competitions
- A rich and varied content
- A new platform with an attractive design
- Great visibility through the company's various media
- A conscientious and passionate team
- Social media distribution
- All types of video games and home entertaining products are represented

Editorial contact: Simon BRUNNER // simon@daily-games.ch

Marketing contact: Claude TALABER // (+41)22 796 23 61 // claudio@daily-media.ch



The Website of Daily Multimédia is dedicated to **new technologies and geek news**. It covers many topics through news, reviews, documented reports and contests.

Computers, smartphones and tablets, Internet, photography, household and electronic appliances, everything related to audio and TV/video, etc. **no longer hold any secret** for our team and even less for our readers, who are curious to know everything about **the ever-changing world of high tech**.

The frequently updated website of Daily Multimédia gains, through its editorial diversity, a large audience made of **geeks of all ages, but also takes into consideration the interest of the parents**. It provides a wide range of cultural news, nationally and internationally.

Highlights :

- Frequently updated website
- Diversity of its readers
- Regular competitions
- A rich and varied content
- A new platform with an attractive design
- Great visibility through the company's various media
- A conscientious and passionate team
- Social media distribution
- All types of entertaining products are represented

Editorial contact : Jérémie CHARPILLOZ // jeremie@daily-multimedia.com

Marketing contact : Claude TALABER // (+41)22 796 23 61 // claudio@daily-media.ch



The website of Daily Family, the newest site of Daily Media, was created to respond to the curiosity of the whole family. It tackles various topics, from books to DVD and movies, from music to local cultural events (fairs, shows, etc.), but also the newest video games and toys. The idea is to be of interest for the children of all age, but also for mom and dad. The website has also made room for a giveaway section, where lots of prizes can be won. Frequently updated and covering a wide spectrum of topics, the website Daily Family is now entering its second year and hopes to offer the whole family enough ideas of entertainment so that no one gets bored.

Highlights :

- Regularly updated
- Many giveaways
- Various topics
- Distribution of the articles on the social networks
- Readership : 6 to 66 years old

Editorial contact : Jérémie CHARPILLOZ // jeremie@daily-multimedia.com
Marketing contact : Claude TALABER // (+41)227962361 // claudet@daily-media.ch

Target audience

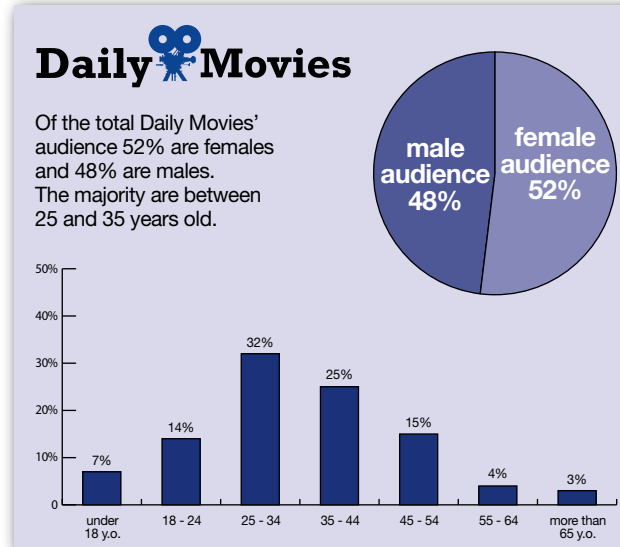
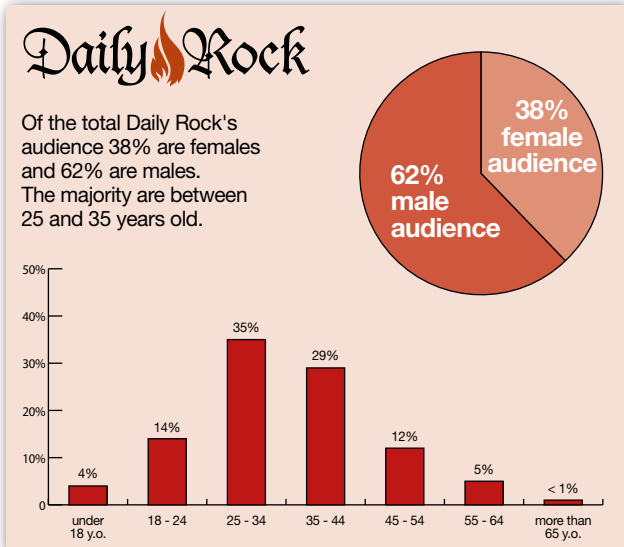

You can see at a glance the target audiences for our various digital media platforms. and the age groups of our users.

Through their cultural diversity, Daily Media Sàrl' Websites provide unique communication channels to our customers and partners wishing to reach a wide audience, made up equally of men and women of all ages and social backgrounds.

The websites traffic statistics are available upon request.

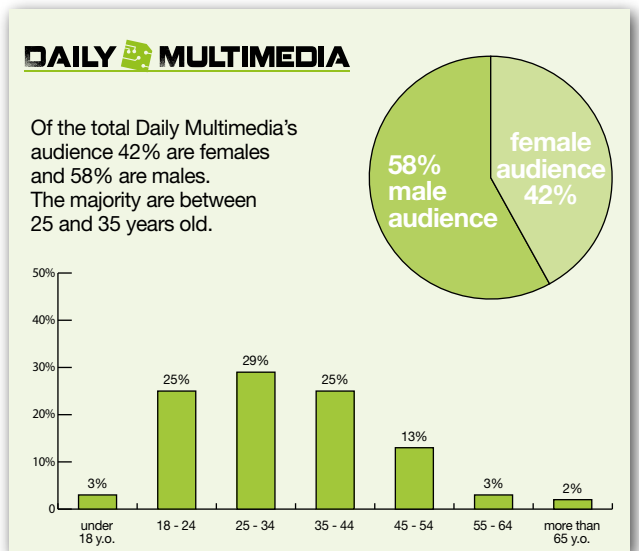
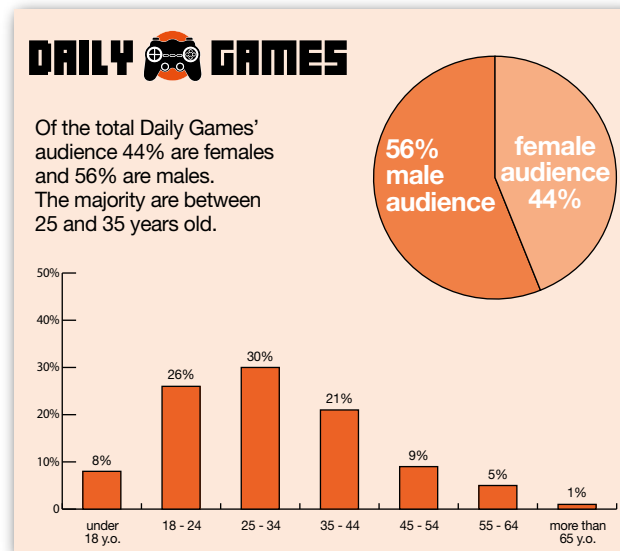
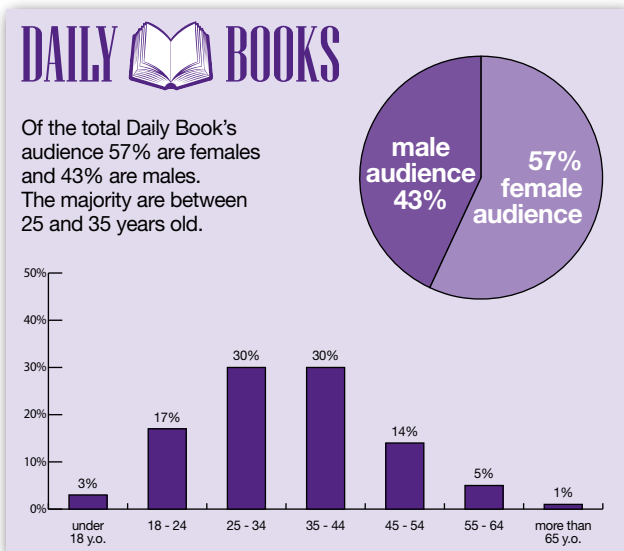

Online ads

Ad banners are available in three sizes on our **five Websites (Daily Rock, Daily Movies, Daily Books, Daily Games and Daily Multimédia)**. Leaderboard, Skyscraper and Full-page ad.

Leaderboard 728 x 90 pixels - max 90 ko



Skyscraper 160 x 600 pixels - max 90 ko



Full-page ad 1500 x 1000 pixels - max 500 ko



Other formats: information available on request. The indicated prices are in Swiss francs (CHF) exclusive of the 8% VAT.

Online ads pricing

Ads prices are the same for our **five** Websites: **Daily Rock, Daily Movies, Daily Books, Daily Games and Daily Multimédia.**
They decrease according to display time and number of websites.

		1 website		additional website		5 websites
Leaderboard	1 week	200 CHF		+ 170 CHF		790 CHF
	2 weeks	340 CHF		+ 290 CHF		1'350 CHF
	3 weeks	460 CHF		+ 390 CHF		1'800 CHF
	4 weeks	560 CHF		+ 475 CHF		2'200 CHF
Skyscraper	1 week	150 CHF		+ 125 CHF		585 CHF
	2 weeks	255 CHF		+ 215 CHF		1'000 CHF
	3 weeks	345 CHF		+ 290 CHF		1'350 CHF
	4 weeks	420 CHF		+ 360 CHF		1'650 CHF
Full-page Leaderboard + Skyscraper + Background	1 week	500 CHF		+ 425 CHF		1'980 CHF
	2 weeks	850 CHF		+ 720 CHF		3'350 CHF
	3 weeks	1'250 CHF		+ 1'060 CHF		4'940 CHF
	4 weeks	1'600 CHF		+ 1'360 CHF		6'300 CHF

The indicated prices are in Swiss francs (CHF) exclusive of the 8% VAT.
Ads files may be submitted via email in GIF or JPEG format. We can create your ad at an extra cost of 50 CHF.

Our additional services

The image features a central background image of a man with a beard and tattoos singing into a microphone. Overlaid on this are several promotional elements:

- Movie Posters:**
 - BILLIE JOE + NORAH foreverly** OUT NOW
 - BELLE LA BÊTE** SORTIE LE 26 JUIN EN DVD ET BLU-RAY
 - EL PINTOR** OUT NOW!
 - A GOOD DAY TO DIE HARD** (with Bruce Willis)
- Program Guide (la parenthèse):**
 - février - mars
 - 21.02 Sons of Noel and Adrian (UK)
 - Les Niveaux
 - 28.02 Hong Kong Dong (B)
 - 01.03 The Rodéo (F)
 - 02.03 Christine and the Queens (F)
 - 08.03 Scarlett O'Hanna (F)
 - Voix de Fête off!
 - 14.03 3 Minutes sur Mer (F)
 - 16.03 Olivier Depardon (F) + NADJ (F)
 - 30.03 Hold your Horses (F)
 - 18.04 Tall Ships (UK)
 - la parenthèse - grand-rue 23bis - CE-1160 Nyon
 - info@la-parenthese.ch
 - www.reverbation.com/venue/la-parentheseonyon
 - www.facebook.com/la-parentheseonyon
- Language Selection Diagram:**
 - ANGLAIS (UK flag)
 - ESPAGNOL (Spain flag)
 - ITALIEN (Italy flag)
 - FRANÇAIS (France flag)

Translations

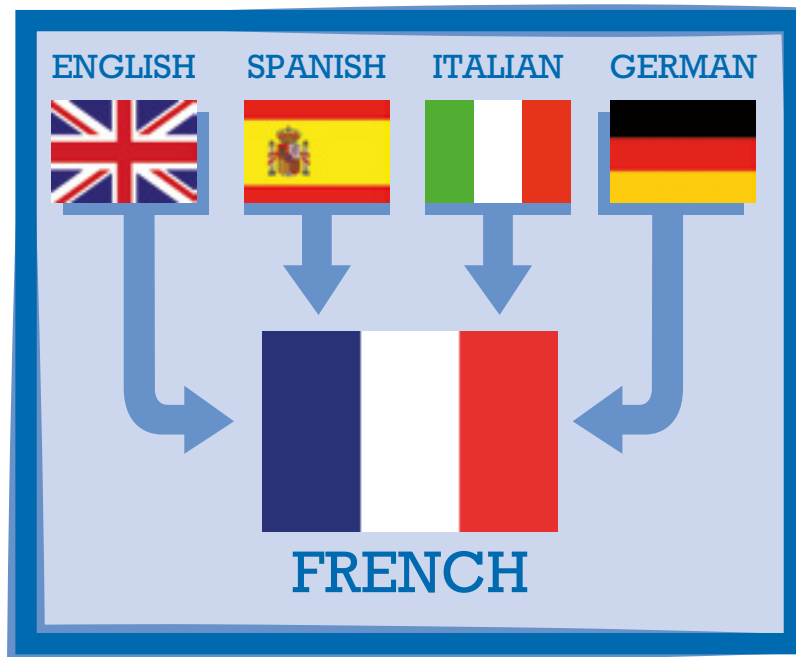

Daily Media can translate your press releases and other documents from English, Spanish, Italian or German into French.

- We are specialized in entertainment (music, movies, video games, etc.)
- The minimum rate is 3 CHF per line
- Scheduled contracts on request
- References : EA Games, ABC Softwares, Ascot Elite, etc.

Photography



Want to create an album and need a shoot **in a studio or in your own environment**? Planning a special event and need **high-quality photographs**?

Look no further! Our team of experienced photographers is ready to cover your events, create photos and deliver promotional shoots throughout the French-speaking part of Switzerland.

- Photographers specialized in studio photography and photo coverages
- References: Greenfield Festival, Les Docks, L'Usine, etc.

Our prices :

- Shooting : 200 CHF / hour
- Photo coverage : on quotation

Our offer :

- We will provide an Internet link in 24 hours or a DVD containing the pictures in native format and Web format for your promotional use
- High-quality pictures
- Photographers suitable for your needs

Graphic Design



You can also let us do the creative work for you and give your design projects to our team of visual communication professionals.

We will create your ads for the newspapers and webzines and we are at your service as a reliable properly qualified partner, helping you to develop flyers, posters, albums covers...

Our prices :

- There will be an extra cost of 20% of advertising price described in pages 18 to 20 for the design work
- From CHF 75.- / hour for any other design work

Any request will be studied, and we will send you a quotation!

Daily Promotion

Are you a music band or a festival at the decisive moment of media promotion? Look no further: Daily Promotion will take care of everything!

Bands :

Media Promotion in the French-speaking and German-speaking parts of Switzerland: newspapers (general and specialized press), radios (regional, webradios), television (local and national).

Some press releases may be sent upon request to the most important festivals and Swiss clubs.

- Targeted mailing lists
- Band news will be covered for 3 months
- A review of your album and an interview of your band in the Daily Rock or Daily Movies issue of your choice
- Promotion via social networks

Festivals :

Media Promotion in the French-speaking and German-speaking parts of Switzerland: newspapers (general and specialized press), radios (regional, webradios), television (local and national).

Daily Promotion can also provide information between a German-speaking festival with the French-speaking press, and vice-versa.

- Large mailing list in the French-speaking and German-speaking parts of Switzerland
- Press releases sent to a list of stakeholders
- News & events before and during the festival
- Preview about your festival in the Daily Rock or Daily Movies issue of your choice
- Published news on the Website of Daily Rock or Daily Movies
- We will indicate your festival dates on the online calendars and promote it via our social networks

Any request will be studied and we will send you a quotation suitable to your needs.

Contact us

D a i L Y
m e d i a

David MARGRAF
Carlos MÜHLIG

dave@daily-media.ch
carlos@daily-media.ch

(+41) 22 796 23 61
(+41) 22 796 23 61

Daily  Rock

David MARGRAF

marketing@daily-rock.com

(+41) 22 796 23 61

Daily  Movies

Carlos MÜHLIG

marketing@daily-movies.ch

(+41) 22 796 23 61

DAILY  BOOKS

Romain KAPPS (editorial)
Claude TALABER (marketing)

bede@daily-books.com
claudio@daily-media.ch

(+41) 22 796 23 61

DAILY  GAMES

Simon BRUNNER (editorial)
Claude TALABER (marketing)

simon@daily-games.ch
claudio@daily-media.ch

(+41) 22 796 23 61

DAILY  MULTIMEDIA

Jérémie CHARPILLOZ (editorial)
Claude TALABER (marketing)

jeremie@daily-multimedia.com
claudio@daily-media.ch

(+41) 22 796 23 61

D a i L Y
m e d i a